

FREESTANDING ROOF EDGE PROTECTION

Operation and Maintenance Manual



Issue No. 001. July 2017

Contents

1.0 General

- 1.1 Intended use
- 1.2 Service life
- 1.3 Duty of care

2.0 Assembling Roof Edge Protection

- 2.1 Parts list
- 2.2 System overview
- 2.3 Assembly guide

3.0 Maintenance

- 3.1 Periodic inspection
- 3.2 Cleaning
- 3.3 Maintenance

4.0 Inspection records

5.0 Attachments

- 5.1 Inspection Log

These Operating & Maintenance Instructions are a component part of any Freestanding Roof Edge Protection system and must be used whenever the system is assembled. At no time should any pages from these instructions be removed.

1.1 Intended use

The Roof Edge Protection system is a collective freestanding guardrail that has been designed to provide an effective barrier for flat or nearly flat roofs with a maximum pitch of 10°.

The Freestanding Roof Edge Protection system is a permanent barrier.

The Freestanding Roof Edge Protection system is only regarded as being fit for its intended use if the following conditions are complied with:

- The Freestanding Roof Edge Protection is governed by statutory regulations and guidelines and installation personnel shall be familiar and adhere with the following:
 - o EN ISO 13374 Part A
 - o HSG 33 – Health and Safety in roof work.
 - o HSE INDG 284 – Working on Flat Roofs.

The Freestanding Roof Edge Protection is designed to withstand a maximum horizontal load applied perpendicular to the top rail of 300N without deflecting more than 55mm. As required by EN 13374 Part A.

The Freestanding Roof Edge Protection system is for use on Asphalt using Spartan or Elastomer tiles, Mineral Coated felt roofs or PVC membranes.

1.2 Service life

Metalwork:	Will deteriorate with time and atmospheric conditions, but generally indefinite.
PVC Counterweights:	20 years at -10° to + 40°
Rubber pads:	20 years at -10° to + 40°

1.3 Duty of care

The Building Owner and / or Building Manager have a duty of care for the structures they have responsibility for, and in particular they shall ensure:

The Freestanding Roof Edge Protection system is/should:

- Only be used as intended.

- Checked regularly
- Only used by trained and authorised personnel.
- Provided in a reliable and fault free condition.
- Where possible be linked into the Buildings Lightning Protection system.

That operatives have:

- Personal Protective Equipment available for use.
- Personal Protective Equipment is checked regularly.
- A current Operation and Maintenance Manual located adjacent to the installation.
- All relevant operatives understand the contents of the Manual.
- Installation operatives are duly instructed in all health and safety matters before initial commencement of work, and once a year thereafter. In addition to this Installation operatives are to have adequate PPE to prevent falls from height during installation.
- All installation and use should cease when the average wind speed reaches 23 mph (gusting to 35mph or more).

2.1 System Parts list.

- | | | |
|-----------|---------------------------|------------|
| • RE00T40 | Standard Post | 12 kg each |
| • RE11P40 | 2000mm long Counterweight | 32 kg each |
| • RE12P40 | Run End Counterweight | 68 kg each |

2.2 System parameters – Un-Restrained – EN 13374 Part A

- RE00T40 posts can be spaced up to a MAXIMUM of 2000mm centres.
- At free ends on all systems, RE12P40's are required to be fitted to the first & last post in a system. Immediately adjacent to RE12P40, a RE11P40 is required to be fitted, followed by an RE00T40, to complete the system configuration.
- On closed installations, i.e. installations which have no free ends, there are no requirements to fit RE12P40.

- The Roof Edge Protection system requires an RE11P40 at 4000mm maximum centres.
- On The Freestanding Roof Edge system, the cross-rail tube connections should be made using A8 External Connectors.

2.3 ASSEMBLY GUIDE

STANDARD UPRIGHT (RE00T40)



This is supplied already assembled at the correct height (1100mm) with the Base Foot & Saddle Clamps set at the correct position.

LAYING OUT SUPPORT LEG AND MAIN RAIL TUBES

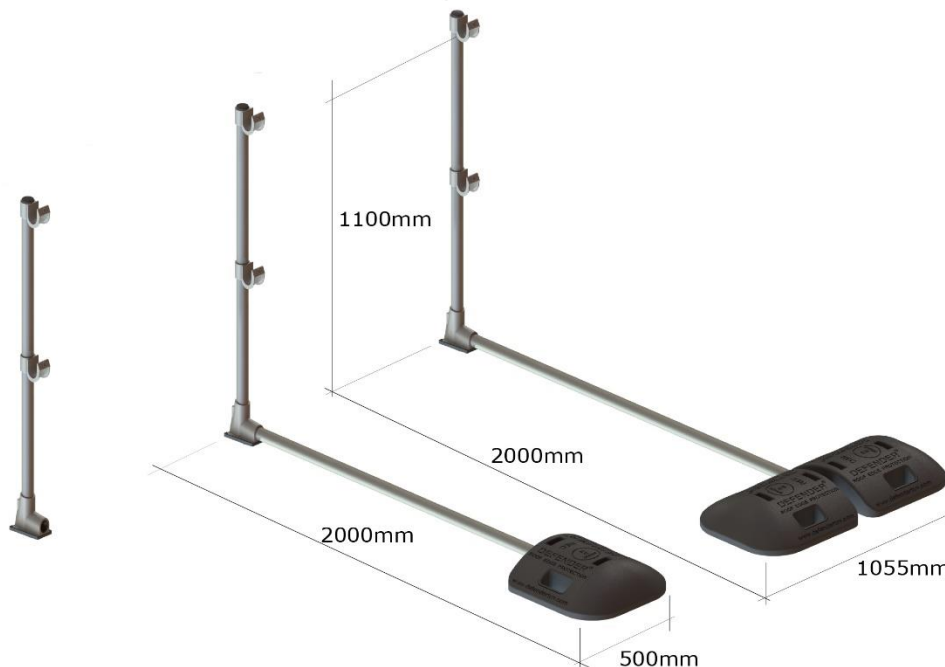

Lay out the equipment in approximately the positions shown below. Always ensure that you and the equipment are at a safe distance from the roof edge. It is recommended that this distance is no less than 2m.

Lay out two Main Rail Tubes side by side and in a continual line, for the whole length of the required guardrail (ensure these do not roll towards the roof edge). Then start laying out the upright units. If your start position is from a corner, start laying out the uprights 0.5m less than the maximum of the following centres. Carry on laying out the Support Legs for the required length of guardrail.

STAGE 1

Starting at least 2m away from the roof edge at the corner, stand up the two uprights.



STAGE 2

Place a Main Rail Tube into the bottom Saddle Clamp of each of the standing legs. Position the tube so there is at least 60mm extending past the Saddle Clamp and tighten the Grub Screws. These are located on the front of the Saddle Clamp.

Place the second Main Rail Tube into the top Saddle Clamp, positioning the tube as before, leaving at least 60mm of the tube extending past the Saddle Clamp and tighten the Grub Screw of the Saddle Clamp.

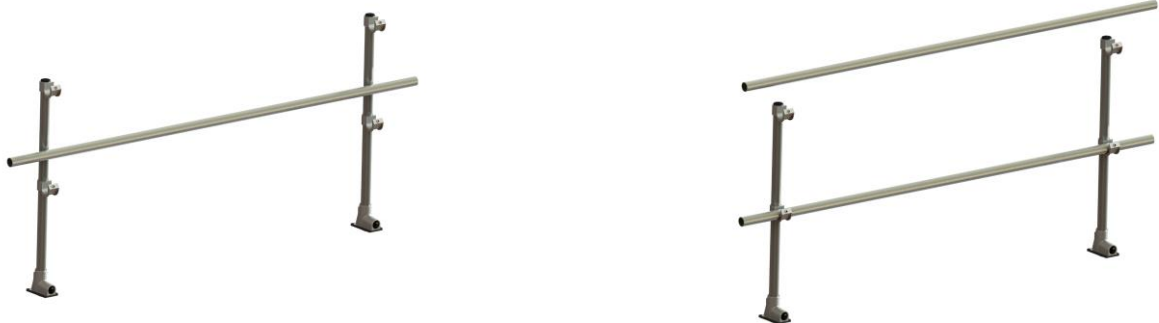

STAGE 3

Form a corner via connecting 2No A6 90° Corners to one end of each of the Main Rail Tubes. Position a further Support Leg 5m from the corner. Slide a Main Rail Tube into the bottom Saddle Clamp and 90° Corner. Slide a Main Rail Tube into the top Saddle Clamp and 90° Corner. Tighten the grub screws of all clamps.



STAGE 4

Working in pairs carefully lift the assembled bay and walk towards the leading edge. Carefully place the bay in the desired position and slide the corresponding Counter Weight tube into the Base Foot.

Always ensure the bay is being held in position whilst carrying out this part of the assembly.



STAGE 5

Intermediate uprights. Legs, Tubes & PVC weights are required at the upright following the double weighted free end combination and then at every other upright position. To install, slide 1No. Cantilever Tube into the Base Foot. Do not tighten at this stage. Place 1No. A58 Collar in the front slot of the PVC Counter Weight. Slide 1No. PVC Counter Weight on to the free end of the Cantilever Tube. Line and level guardrail. Tighten all grub screws.



STAGE 6

Working away from the corner slide an A8 External Connector on to the top and intermediate Main Rail Tubes. Ensure the External Connectors are staggered either side of the upright to ensure no two couplers line up within the same bay. As far as possible only use one External Connector per bay. Stand up the next Support Leg at the desired position (2m max). Continue with this method of fitting the Main Rail Tube and uprights together for this run of guardrail, remembering to connect the intermediate Cantilever Tubes and PVC Counter Weights to the uprights as you proceed.



STAGE 7

Free Standing End Details Slide 1No. A2 Short Tee on to the free end of the Cantilever Tube. Do not tighten at this stage. Slide the solid bar through Short Tee and tighten the grub screw holding this tube into position. Place 2No. Collar in the front slot of each PVC Counter Weight. Slide 1No. PVC Counter Weight on to each free end of the solid bar.

A



B



C



WARNING

Under no circumstances should any person be anchored to the system for fall arrest purposes. Further, components such as timber infill, advertising boards, polyethylene sheets must not be fixed to the system.

CLOSED INSTALLATION

SINGLE COUNTERWEIGHT INSTALLATION PROCEDURE

1. Lay the first post (**RE00T010**) at the start position
2. Attach a counterweight with 1575mm long tube to the first post

Single counterweight
RE11P40 or RE11P40S

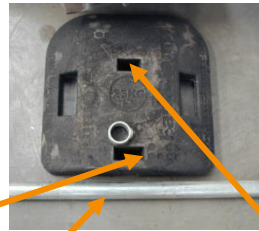

The locking collar goes into the first hole in the counterweight. The tube passes through the collar and is in position when the end of the tube is visible in the second hole. The setscrew on the locking collar is then tightened and the setscrews on the post base are tightened.

3. Position the second Post this does not require a counter weight.
4. Position the third post and attach a counterweight.
Continue this procedure with a free post and then a weighted post.

CRADLE AND TUBE INSTALLATION PROCEDURE

5. Lower the tube into position in the cradle tighten the setscrew to a recommended torque of 39 Nm.



NOTES

Make certain that the maximum spacing for posts is no greater than those specified.

Make certain that the maximum spacing for counterweights is no greater than those specified.

Apart from at a direction change the joining of the tubes must be in separate bays for the top and middle rail.

FREE END INSTALLATION

RUN END COUNTERWEIGHT INSTALLATION PROCEDURE

1. Lay the first Post at the start position.
2. Attach a Run End Counterweight assembly with 1575mm long tube to the first Post.

The Run End Counterweight comprises 2 counterweights 2 locking collars 1 short tee 1575mm tube and a 900mm solid bar.

Run End Counterweight
RE12P40

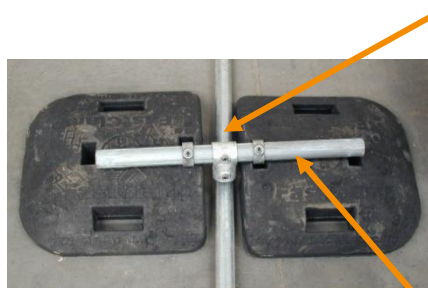

As with the single counterweight insert the locking collar into the first hole. The solid bar then passes through the locking collars until it is visible in the second hole. The short tee is positioned on the solid bar between the 2 counterweights. The setscrew on the locking collars is then tightened and the setscrew on the short tee is tightened. The 1575mm tube is then placed into the short tee and the other end into the base of the post and the setscrews tightened.

3. Position the second post and attach THE CORRECT counterweight depending on system being used.
 4. Position the third Post. This does not require a Counterweight on Economy or Plus systems.
 5. Position the fourth Post and attach the correct counterweight.
- Continue this procedure according to the system being used with a free post and then a weighted post or a weighted post every time.

Ensure that there is a Run End Counterweight and adjacent Single Counterweight at each free end.

NOTES

Make certain that the maximum spacing for posts is no greater than those specified.

Make certain that the maximum spacing for counterweights is no greater than those specified.

Apart from at a direction change the joining of the tubes must be in separate bays for the top and middle rail.

3.1 Periodic inspection

At least once every 12 months a designated competent person shall check the system for:

- Any movement of the system.
- Tightness of setscrews.
- Any corrosion of parts.
- Adhesion of rubber pads.
- Damage to component parts.
- Condition of roof areas adjacent to the installation.

3.2 Cleaning

- System can be cleaned simply by using clean water and a light detergent applied with a hose or by wiping down.

3.3 Maintenance

- The Freestanding Roof Edge Protection system is constructed from Hot Dip Galvanised iron and steel, and PVC counterweights, this makes the product virtually maintenance free.
- Corrosion may occur with time and any signs of oxidisation should be lightly wire brushed and 2 coats of zinc rich paint shall be applied.
- Fixings should be immediately replaced on evidence of any deterioration.

4.0 Inspection Records

It is important that a record of regular inspections, comments and remedial action is kept, and form 5.1 in the attachment section should be completed and signed after every inspection and action.

5.1 Inspection log

Date	Name of Inspector	Comments	Action	Signature